

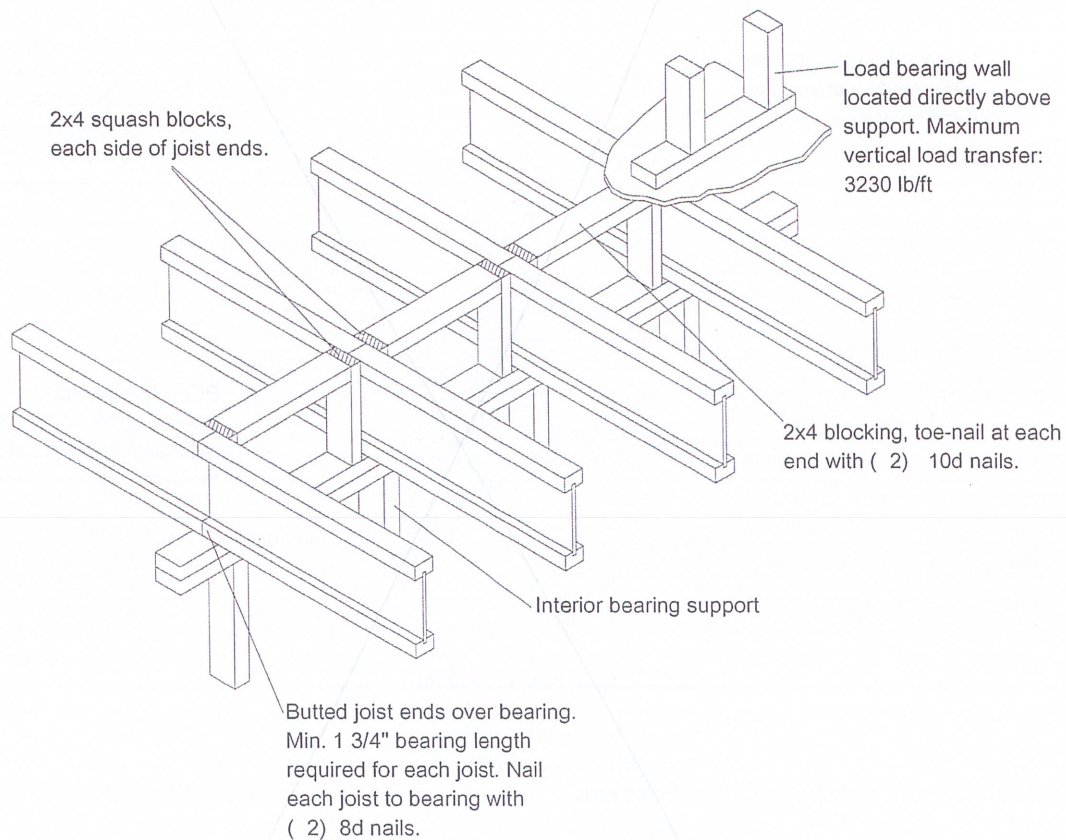

Load Bearing Wall Above - 2x Squash Blocks & Flat Blocking



Notes:

- 1) Nail squash blocks with one 3" (10d) nail into each flange
- 2) This detail is applicable only for construction falling under the NBCC 2015 – Part 9
- 3) Detail shown above provides adequate lateral stability for AJS/BCI joists. Additional lateral resistance may be required for high wind and /or seismic load areas; consult with project's design professional of record.

DETAIL 2'



Non - Load Bearing Partition Wall Above

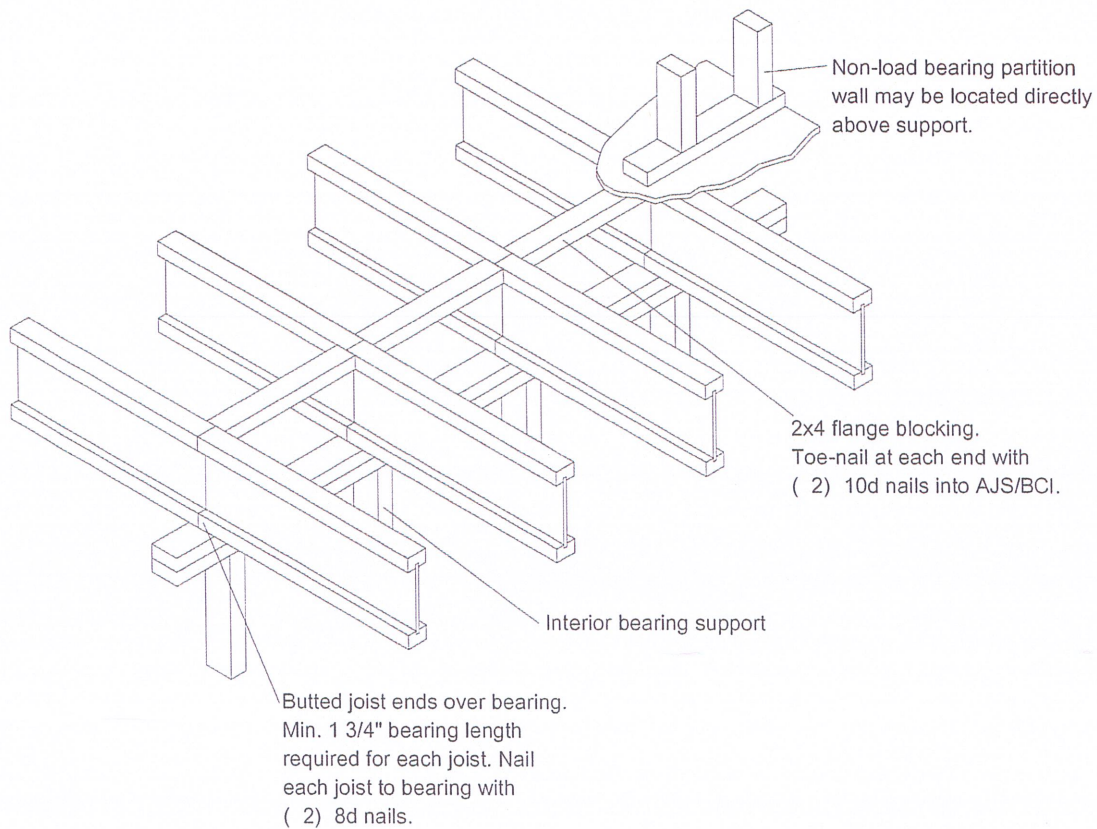

Notes:

- 1) This detail is applicable only for construction falling under the NBCC 2015 – Part 9
- 2) Detail shown above provides adequate lateral stability for AJS/BCI joists. Additional lateral resistance may be required for high wind and /or seismic load areas; consult with project's design professional of record.

DETAIL 3